

## Specifications & Measurements

*\*Subject to change*

Ram ProMaster 2500 SLT+  
Window Van 159" WB High Roof

- 8 Passenger Seating
- Fully Insulated - Quiet Ride
- Trailer Towing Package
- Maximum Cargo Capacity - 2,049lbs (assuming 8 standard passenger seating)\*
- Minimum Cargo Capacity - 999lbs (assuming 8 standard passenger seating)\*

\*Maximum is defined as driver/no other passengers

\*Minimum is defined as all 8 passengers are present in vehicle

**EXCLUSIVE FENTON Q PRO PROGRAM WARRANTY**  
**5 YEAR/100,000 MILE - POWERTRAIN**  
**3 YEAR/36,000 MILE - BUMPER TO BUMPER**  
**3 YEAR/UNLIMITED MILE - FENTON SHIFT-N-STEP**  
**3 YEAR/UNLIMITED MILE - BRAUN WHEELCHAIR LIFT**  
**3 YEAR/36,000 MILE - AIR CONDITIONING & HEATING**  
**FENTON WARRANTY COVERAGE ON UPFIT**  
Anything not specified under manufacturer's warranty  
**1 YEAR/12,000 MILE**

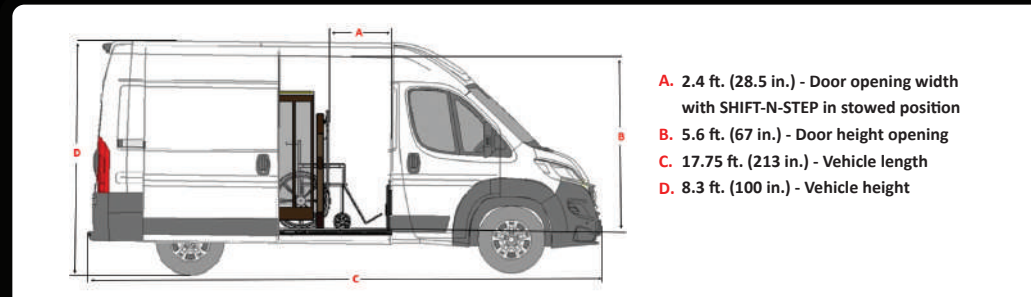

- A.** 2.4 ft. (28.5 in.) - Door opening width with SHIFT-N-STEP in stowed position
- B.** 5.6 ft. (67 in.) - Door height opening
- C.** 17.75 ft. (213 in.) - Vehicle length
- D.** 8.3 ft. (100 in.) - Vehicle height

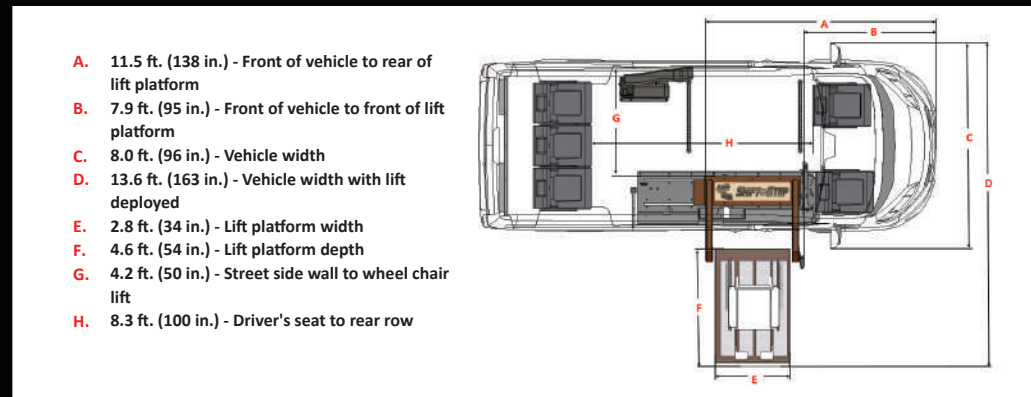

- A.** 11.5 ft. (138 in.) - Front of vehicle to rear of lift platform
- B.** 7.9 ft. (95 in.) - Front of vehicle to front of lift platform
- C.** 8.0 ft. (96 in.) - Vehicle width
- D.** 13.6 ft. (163 in.) - Vehicle width with lift deployed
- E.** 2.8 ft. (34 in.) - Lift platform width
- F.** 4.6 ft. (54 in.) - Lift platform depth
- G.** 4.2 ft. (50 in.) - Street side wall to wheel chair lift
- H.** 8.3 ft. (100 in.) - Driver's seat to rear row

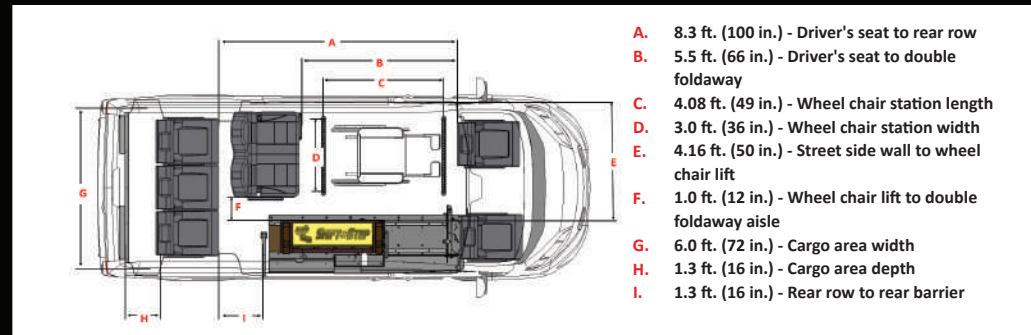

- A.** 8.3 ft. (100 in.) - Driver's seat to rear row
- B.** 5.5 ft. (66 in.) - Driver's seat to double foldaway
- C.** 4.08 ft. (49 in.) - Wheel chair station length
- D.** 3.0 ft. (36 in.) - Wheel chair station width
- E.** 4.16 ft. (50 in.) - Street side wall to wheel chair lift
- F.** 1.0 ft. (12 in.) - Wheel chair lift to double foldaway aisle
- G.** 6.0 ft. (72 in.) - Cargo area width
- H.** 1.3 ft. (16 in.) - Cargo area depth
- I.** 1.3 ft. (16 in.) - Rear row to rear barrier

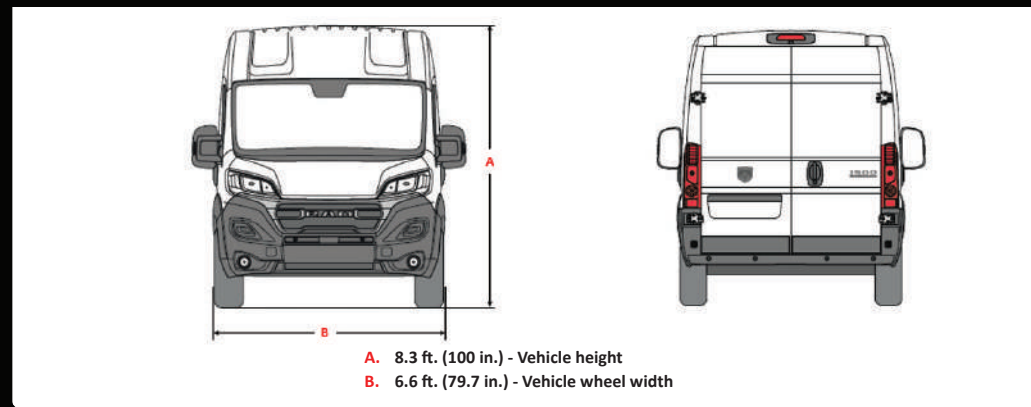

- A.** 8.3 ft. (100 in.) - Vehicle height
- B.** 6.6 ft. (79.7 in.) - Vehicle wheel width

# FENTON

## InnovateElevate

### ACCESS MAX GUIDE

Ram ProMaster 2500 SLT+ 8 passenger Van



Access **MAX**

# FENTON

InnovateElevate

[www.fentonmobility.com](http://www.fentonmobility.com)

# MAXIMIZING ACCESSIBILITY

INTRODUCING THE ACCESS MAX BROUGHT TO YOU BY FENTON MOBILITY.

This vehicle includes the Patented **Shift-N-Step**, which is the first ever state-of-the-art ADA compliant vehicle system to allow **TOTAL ACCESS FOR ALL**.

The Shift-N-Step creates a truly "Cross-Over" vehicle allowing curbside service for everyone, anytime, anywhere. One door with one system will now allow both wheelchair and ambulatory passengers in the vehicle. With the Shift-N-Step dual entry system, you no longer need to have your vehicle structurally modified at either the front door position or the side door location to provide ambulatory access.

Due to the van not being structurally modified, you minimize service and warranty issues minimizing the cost of ownership overall.

Find out more about Shift-N-Step



## 8 PASSENGER SEATING, WITH REAR SEATING FOR FIVE...

Driver Side Running Board with Blackout Package



Manor Oak Flooring with Shift-N-Step Barrier



Rear Seating for five plus Wheelchair, USB Charging Stations and Cup Holders



Double Bellagio Foldaway Seats with Fenton Mounting Plate and Black L Track



Three Heated Eleganza Trieste Reclining Seats



Driver and Passenger Vinyl Covers with Diamond Stitch



Explore our current list specifications & options



### FEATURES

- SHIFT-N-STEP DUAL ACCESS LIFT
- DRIVER & CARGO SIDE RUNNING BOARD WITH BLACKOUT PACKAGE
- MANOR OAK FLOORING WITH SHIFT-N-STEP BARRIER
- USB CHARGING STATIONS AND CUP HOLDERS
- TRAILER TOW PACKAGE INCLUDED

### COMFORT

- Three Heated Eleganza Trieste Reclining Seats
- Double Bellagio Foldaway Seat
- Driver and Passenger Vinyl Covers with Diamond Stitch
- Fully Insulated - Quiet Ride

### AMERICAN MADE

- Manufactured and upfit in our 90,000sq/ft facility in Randolph, NY