

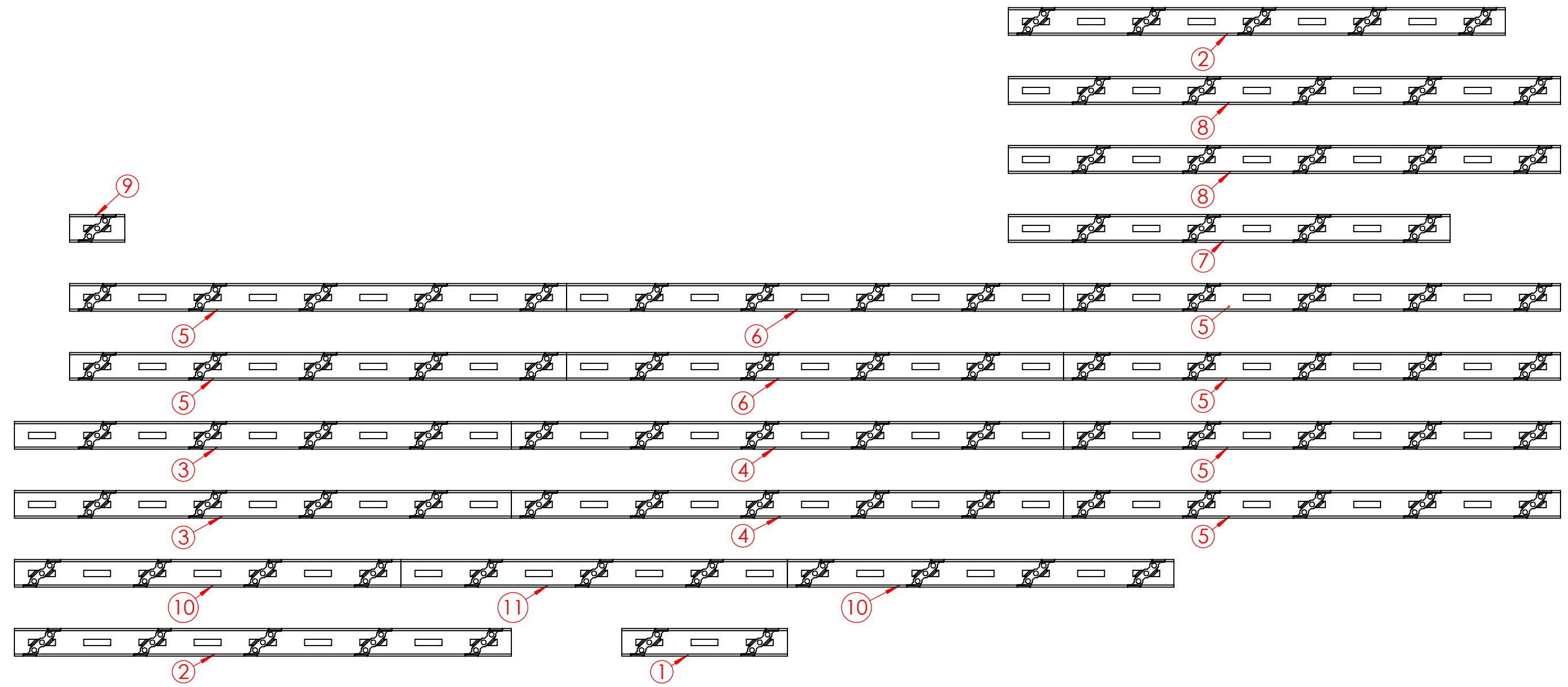

REVISION					
REV.	DESCRIPTION	DRAWN BY	DATE	APPROVED BY	DATE
A	INITIAL RELEASE	R.AUCOIN	10/30/23		



NOTE: REFERENCE CAD MODEL FOR ALL UNDIMENSIONED FEATURES

ITEM NO.	PART NUMBER	DESCRIPTION	QTY.
1	XTR015XP-XW	15" ABILITRAX RAIL WELDMENT	1
2	XTR045XP-XW	45" ABILITRAX RAIL WELDMENT NO SPLICE	2
3	XTR045XP-XBW	45" ABILITRAX RAIL W/ ONE SPLICE	2
4	XTR050XP-XAW	50" ABILITRAX RAIL WELDMENT W/ TWO SPLICE	2
5	XTR045XP-XAW	45" ABILITRAX RAIL WELDMENT W/ ONE SPLICE	6
6	XTR045XP-XDW	45" ABILITRAX RAIL WELDMENT W/ TWO SPLICE	2
7	XTR040XP-XW	40" ABILITRAX RAIL WELDMENT	1
8	XTR050XP-XW	50" ABILITRAX RAIL WELDMENT	2
9	XTR005XP-XW	5" ABILITRAX RAIL WELDMENT	1
10	XTR035XP-XBW	35" ABILITRAX RAIL WELDMENT ONE SPLICE	2
11	XTR035XP-XAW	35" ABILITRAX RAIL WELDMENT TWO SPLICE	1

GAUGE: N/A	PART NUMBER: AAT4Z0NSLRK	REV A
MATERIAL: N/A	DESCRIPTION: TRANSIT 140 SNS LASER CUT RAIL KIT	
FINISH: PLATING	 	
TOLERANCES (UNLESS OTHERWISE NOTED) FABRICATED: ANGULAR: ± 1° TWO PLACE DECIMAL: ± 0.03 THREE PLACE DECIMAL: ± 0.02 MACHINED: ANGULAR: ± 0.5° TWO PLACE DECIMAL: ± 0.01 THREE PLACE DECIMAL: ± 0.005	SCALE: 1:10	SHEET: 1 OF 1
APPLICABLE TOLERANCE: FABRICATED		