

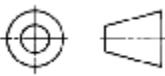

NOTCHES	PART NUMBER	DESCRIPTION	QTY.
12	XTR040XP-XAW	40" ABILITRAX RAIL ONE SPLICE	1
3	XTR035XP-XBW	35" ABILITRAX RAIL WELDMENT ONE SPLICE	5
14	XTR020XP-W	20" STAINLESS ABILITRAX RAIL WELDMENT	3
13	XTR025XP-XAW	25" ABILITRAX RAIL WELDMENT ONE SPLICE	3
6	XTR045XP-XDW	45 " ABILITRAX RAIL WELDMENT W/ TWO SPLICE	3
8	XTR050XP-XAW	50 " ABILITRAX RAIL WELDMENT W/ TWO SPLICE	4
4	XTR045XP-XAW	45 " ABILITRAX RAIL WELDMENT W/ ONE SPLICE	5
0	XTR005XP-XW	5 " ABILITRAX RAIL WELDMENT	1
2	XTR035XP-XAW	35" ABILITRAX RAIL WELDMENT TWO SPLICE	1
5	XTR045XP-XBW	45 " ABILITRAX RAIL W/ ONE SPLICE	3
11	XTR040XP-XW	40 " ABILITRAX RAIL WELDMENT	1
N/A	HF25200625	HEX FLANGE BOLT, 1/4-20 x 5/8"	34
N/A	FN2520SRZN	SERRATED FLANGE NUT , 1/4-20	34
N/A	AAT7DZHWO1K	TRANSIT 170 SNS KIT (FASTENAL #10263-06638)	1

NOTE: REFERENCE CAD MODEL FOR ALL UNDIMENSIONED FEATURES

GAUGE: N/A	PART NUMBER: AAT7SZ00	REV B
MATERIAL:	DESCRIPTION: TRANSIT 170 SNS LASER CUT RAIL KIT	
FINISH: PLATING	 	
TOLERANCES (UNLESS OTHERWISE NOTED)		
FABRICATED: ANGULAR: ± 1° TWO PLACE DECIMAL: ± 0.03 THREE PLACE DECIMAL: ± 0.02 MACHINED: ANGULAR: ± 0.5° TWO PLACE DECIMAL: ± 0.01 THREE PLACE DECIMAL: ± 0.005		
APPLICABLE TOLERANCE: FABRICATED	SCALE: 1:12	SHEET: 1 OF 1